



CHEMICAL SANITIZING ENERGY SAVING SINGLE RACK DISHWASHER

E

Low Temperature Energy Saving Dishwasher



MODEL: E-AH

MODEL: E-C

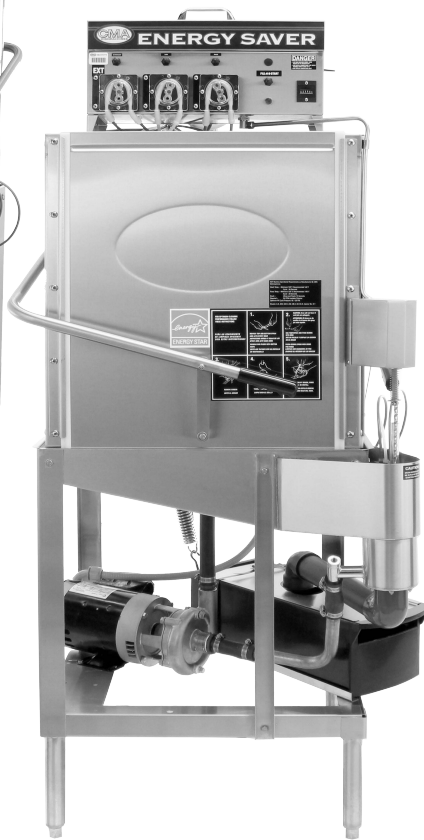

FEATURES

- 40 racks / 160 covers per hour.
- 17" Door opening for maximum clearance.
- Economical to operate. Uses only 1.01 gallons of water per cycle.
- All stainless steel construction assures long life and years of trouble free operation.
- Unique spray arm system features upper and lower stainless steel wash arms with reinforced end caps.
- Top mounted controls include built-in chemical pumps and deliming system for dealing with scale.
- Auto start/stop makes operation safe and easy.
- New integrated scrap tray prevents food soil from entering drain system.
- Airgap fill system.

CONVERTIBLE CORNER TO
STRAIGHT AND STRAIGHT TO
CORNER.

AVAILABLE OPTIONS

- Alternative cycle times
- Solid/Powder Dual Bowl Dispenser
- 3 Door Open
- Stainless Steel Tables
- Alternative Cycle Times
- Alternative Electrical Available
- Slant Shelf 21" x 42"
- Stainless Steel Scrap Trap in lieu of Poly Pro

CMA MODEL: E



Low Chemical Alarm



Temp-Sure
Requires a separate 208-240v
3 phase 40 amp power supply

**CMA
MIZER®**
Registered Trademark





MODEL E

LOW WATER MACHINES

WARNINGS:

- Plumbing connections must be made by a qualified service company who will comply with all available Federal, State, and Local Health, Plumbing and Safety codes.
- CMA recommends utilizing a water softening system to maintain water hardness measurements of 3.5 gpg (grains per gallon) or less. This will assure maximum results and optimum operation of the dishmachine.

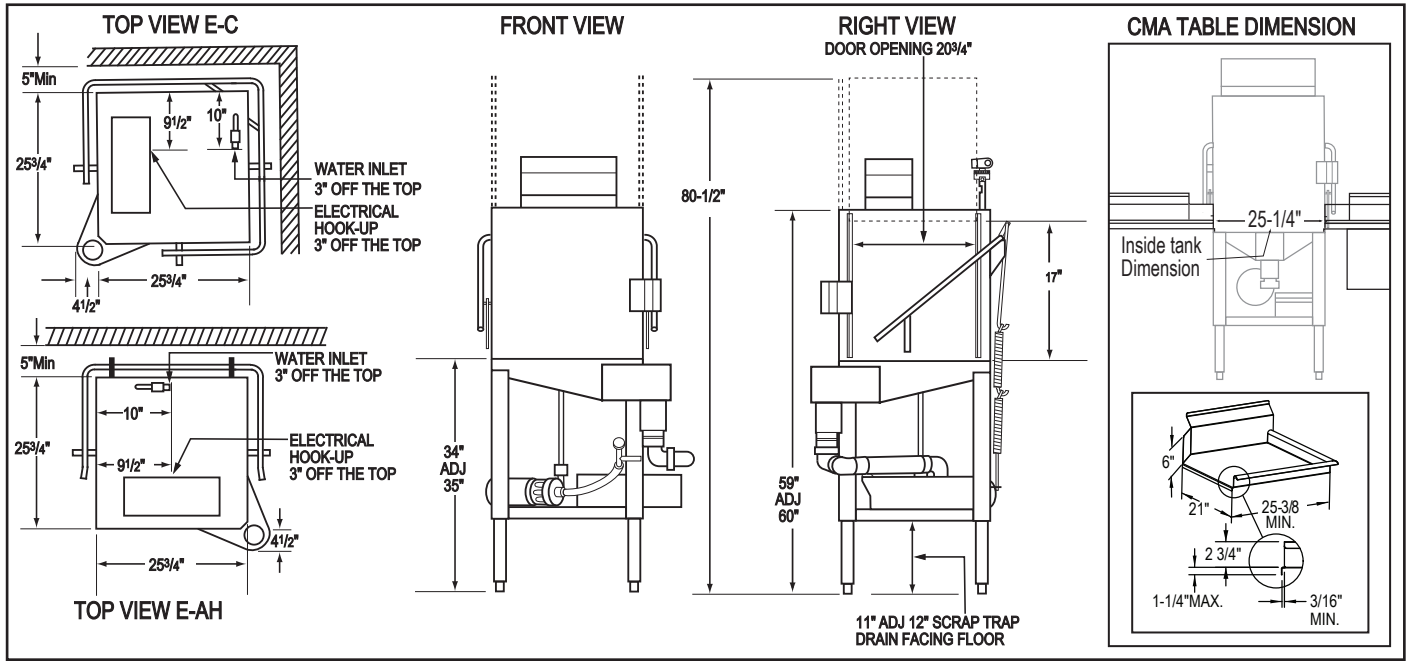

Specifications:

MODEL E	USA	METRIC	MODEL E	USA	METRIC
OPERATING CAPACITY			WASH PUMP MOTORS HP	1	1
RACKS PER HOUR (NSF RATED)	40	40	DIMENSIONS		
OPERATING CYCLE			DEPTH	25-3/4"	(65.4cm)
WASH TIME-SEC RINSE	45	45	WIDTH (OUTSIDE DIMENSION)	25-3/4"	(65.4cm)
TIME-SEC DWELL	30	30	TOTAL HEIGHT WITH DOORS OPEN	80-1/2"	(204cm)
TIME-SEC TOTAL	15	15	STANDARD TABLE HEIGHT	34"	(86cm)
CYCLE TIME	90	90	MAXIMUM CLEARANCE FOR DISHES	17"	(52cm)
PUMP CAPACITY	52 GPM	(197 LPM)	STANDARD DISHRACK DIMENSIONS	1 20" x 20"	1 (50.8 x 50.8cm)
OPERATING TEMPERATURE			ELECTRICAL RATING	VOLTS 115	AMPS 16
REQUIRED	120°F	(49°C)	APPROXIMATE SHIPPING WEIGHT	E-AH/E-C 262#	(118.8kg)
RECOMMENDED	140°F	(60°C)		E-3D 264#	(119.8kg)
WATER CONSUMPTION			SHIPPING DIMENSIONS	PALLET & BOX @ 41" X 41" X 80"	
PER RACK	1.01 GAL.	(3.8 L)			
PER HOUR	40.4 GPH	(152.9 LPH)			
WATER REQUIREMENTS					
WATER INLET	1/2"	(1.27cm)			
DRAIN-I.P.S.	2"	(5.1cm)			

Summary Specifications: Model E

CMA Energy Miser model E low temperature, chemical sanitizing commercial dishwashers meet ETL, UL, and CUL sanitation and construction standards WITHOUT the use of BOOSTER or TANK HEATERS. The model E is constructed entirely of stainless steel. Each unit automatically washes, rinses and sanitizes utensils in standard 19-3/4"-19-3/4" racks. Units come with standard upper and lower stainless steel wash arms. **Note: This machine does not have built-in heaters, therefore produces no steam.**

- Available Models:**
- E-AH Straight
 - E-C Corner
 - E-3-Door

Advisory: CMA does NOT endorse "Tankless On-Demand" water heaters for use on CMA Dishmachine products. CMA DOES endorse, and highly recommends, the standard "tank" style water heaters, sized properly to handle each particular facility with their water heating requirements.



CMA Dishmachines 12700 Knott Street Garden Grove, CA 92841 • 800-854-6417 • 714-898-8781 • Fax: 714-895-2141 • www.cmadishmachines.com

CMA reserves the right to modify specifications or discontinue models without prior notification.

an Ali Group Company



The Spirit of Excellence

© 7-2021 CMA, Inc.